

Sheeting Machinery

Linear Dancer/Progressive Decurler/Vertical Aligner (LPV)

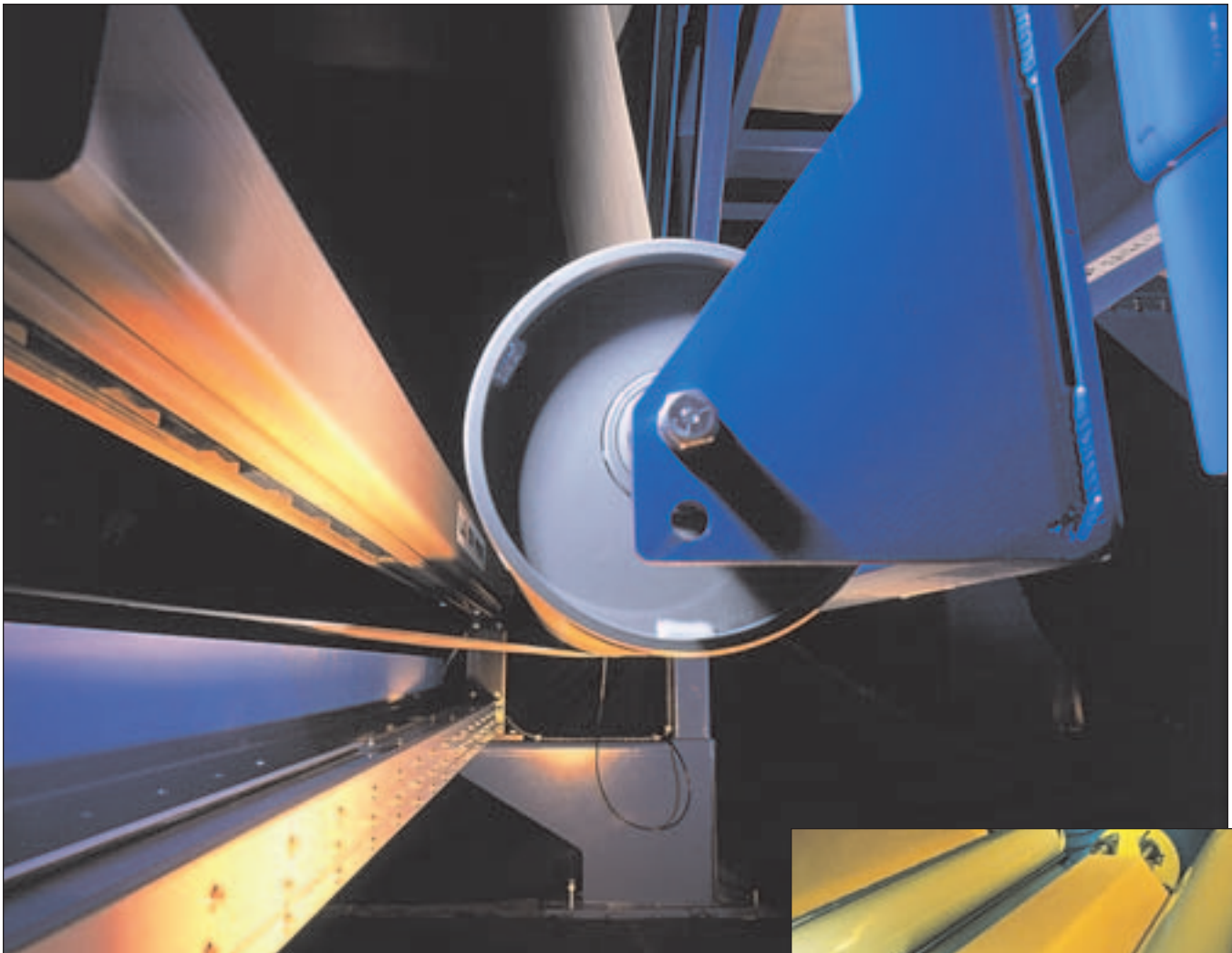

Web Aligner

Features:

- Modular design can be installed on new and existing sheeter lines
- Linear dancer system provides uniform web tension control for increased sheet cut length accuracy
- Progressive decurler with multiple bars is effective for fine paper and board webs
- Vertical web aligner with full width sensor reduces order change set-up time
- Integrated bridge provides clean installation and easy access for reduced web thread-up time
- Baggy-edge roll adjustment compensates for loose web edges

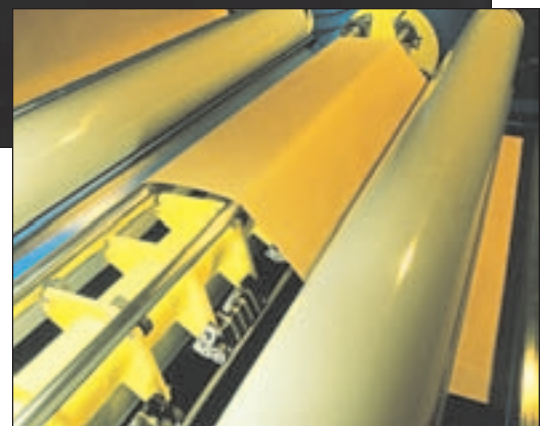

Decurler

Barry-Wehmiller

Sheeting Machinery

Linear Dancer/Progressive Decurler/Vertical Web Aligner (LPV)

Modular Design

The modular design of the LPV integrated system can be configured for delivering single or multiple webs to a converting line. The "clean looking" LPV frame is a self supporting structure that is easy to install over new or existing rollstands. A semi-automatic web trolley reduces thread-up time when running multiple webs of fine paper.

Linear Dancer System

The Linear Dancer System provides uniform web tension control which is crucial for good sheet cut length accuracy. The system uses a digital controller that responds quickly and precisely to roll diameter and line speed changes. Web tension is set electronically on an operator interface with key pad and alpha-numeric display. The system can be configured to run in roll diameter tension control mode for low web tension applications.

Progressive Decurler

The Progressive Decurler has three decurler bars and an idler roll mounted inside a common turret. As the turret rotates decurling bars of progressively smaller diameters engage the paper or board web. As paper rolls unwind the turret rotates further to increase the web wrap and decurling effectiveness of the system. At paper roll change the system can be controlled to move to a neutral position.

Vertical Web Aligner

The Vertical Web Aligner uses a full width laser sensor which requires no operator adjustments during web width changes. The system can be configured to edge or center justify single or multiple webs reducing waste caused by excessive trim losses.

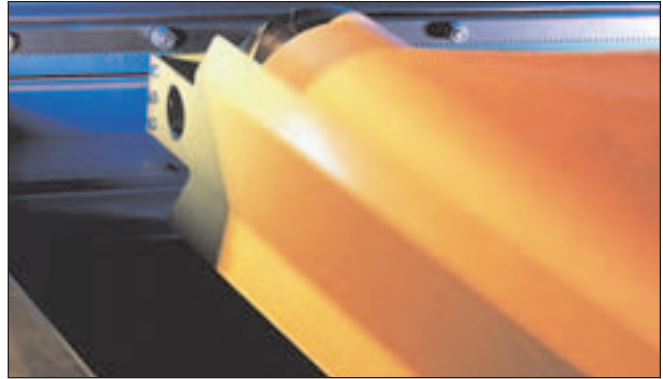
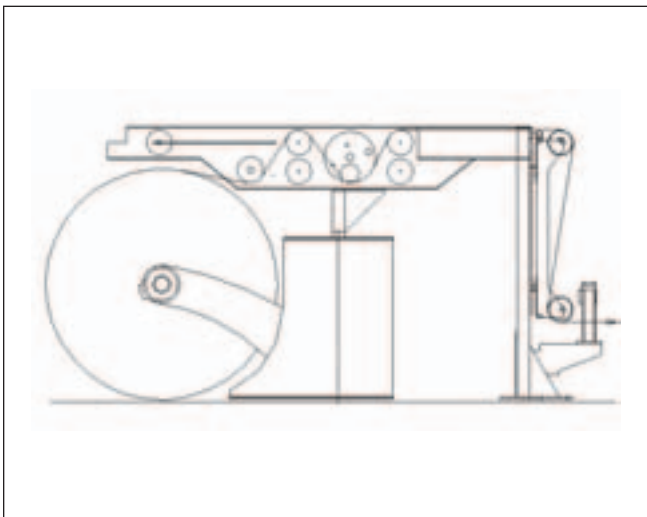

Dancer

Networked Controls

The optional Networked Control System uses a touchscreen display located at the primary sheeter control station. From this control station operators can adjust web tension set-points, decurler positions, web aligner set-points, and Corefinder™ diameters. An animated display provides visual feedback for decurler position and/or dancer position.

Upgradeability

The LPV System can be installed as a complete integrated package or as individual pieces as needed in existing sheeter lines.

Additional Features

- THE MARQUIPWARDUNITED LINEAR DANCER/PROGRESSIVE DECURLER/ VERTICAL WEB ALIGNER (LPV) INTEGRATED PACKAGE PROVIDES AN EFFICIENT WEB CONDITIONING SOLUTION FOR SHEETER LINES.
- OPTIONAL NETWORKED CONTROLS GIVE OPERATORS A SINGLE STATION FOR CONTROLLING MULTIPLE MACHINES
- COREFINDER™ STOPS THE SHEETER LINE AT A PRESET CORE DIAMETER

Specifications

- Linear Dancer: 0.2 to 0.8 N/mm (1 to 4.5 PLI), 330 N (75 lbs.) minimum total web tension
- Progressive Decurler: Bar diameters 12 mm (0.5"), 30 mm (1.25"), and 50 mm (2")
- Vertical Web Aligner: ± 0.38 mm (.015") with a 50 mm (2") input web position error
- Maximum Speed: 1100 fpm
- Electrical Requirements: 5 amps - 115/1/60 5 amps - 110/1/50
- Air Requirements: 80 psi (5.5 bar) less than 2 cfm (60 L/min) typical, 40 cfm (1200 L/min) instantaneous

MarquipWardUnited, Inc.

1300 North Airport Road • Phillips, WI 54555 USA • 715/339-2191
www.marquipwardunited.com • sales@marquipwardunited.com