

# MarquipWardUnited

## SheetWizard



### Key Features

- Dual rotary knife technology in a very economical standardized package, with superb cut quality up to 1000gsm
- Maximum speed of 335 MPM (1100FPM) with curve optimized for digital sheet sizes
- Compact design utilizing an integrated slitter, draw roll, knife cylinders, and outfeed tape belt
- Advanced overlap system for faster speeds with reduced marking
- Versatility to handle a full range of paper and board products. Automatic pallet change
- IEC 61131-3 PC-based control system

## Barry-Wehmiller

# SheetWizard

Flexible and cost effective configurations to suit small and medium sized converters and folding carton plants and mills. The SheetWizard™ can run both paper and board and provides MarquipWardUnited's superior cut accuracy.

## Superior Knife Performance

The MarquipWardUnited SheetWizard is designed around the unique MarquipWardUnited's dual-rotary knife. Tangentially mounted blades on the knife reduce the unsupported blade length and with 1000 GSM loading, the blades can be sharpened while in the machine. The stronger supported blades provide cleaner cuts and less vibration, tuning and sharpening for longer blade life.

## Flexibility

Delivery options such as vacuum sheet tail arrest and driven soft nip snubber tapes, sensitive materials can be delivered at higher speeds without surface marking.

## Options Including:

- Programmable decurling
- Digital assist or automatic slitter setting
- Web Cleaning
- Cut to register
- Reject gate linked to splice detector
- Advanced overlapping for reduced sheet marking
- Automatic pallet change enables the MarquipWardUnited SheetWizard to be configured for the widest range of sheeted applications with future upgrading always possible.

## Standard Features:

- Knife Cylinders Designed For Higher Speeds On Short Sheets
- 460 mm (18in) Diameter Pull Roll System on multi-web applications
- PC Based Control System With Menu Storage And Remote Diagnostics
- Liquid Cooled Motor and Drives using less power and creating less noise

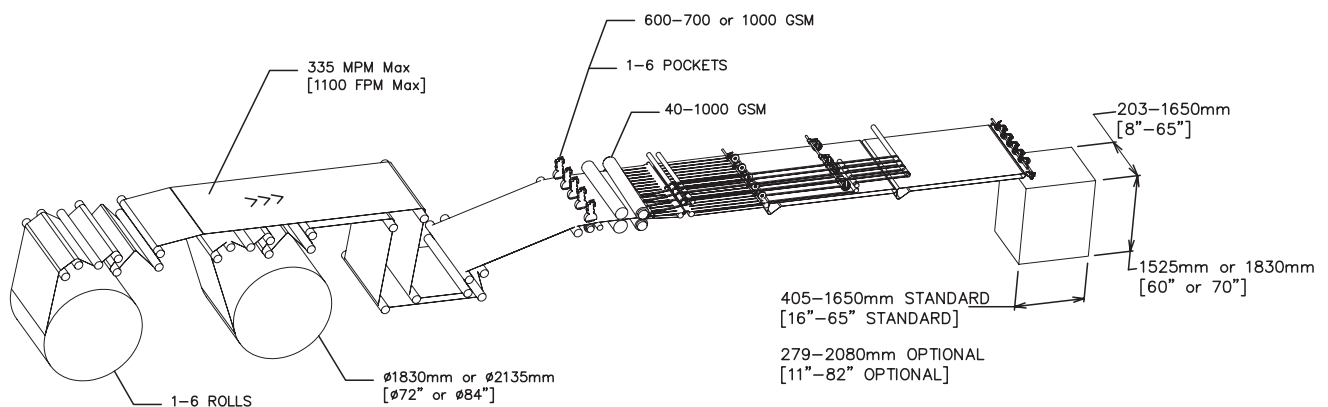
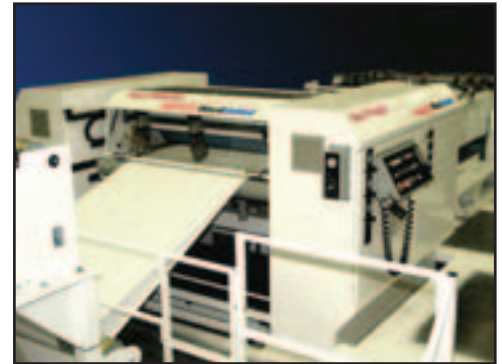

## MarquipWardUnited

1300 North Airport Road, Phillips, WI 54555 USA • (715) 339-2191

www.marquipwardunited.com • sales@marquipwardunited.com